



CLEVELAND FLATS DESIGN GUIDELINES

City of Cleveland, Ohio
March 18, 2022

PROJECT TEAM

City of Cleveland

Joyce Pan Huang
Freddy Collier, Jr.
Anthony Santora
Pegah Nourifard
James DeRosa
James McKnight
Michael Reder

Cleveland Metroparks

Sean McDermott
Sara Maier
John Cardwell
Christopher Cheraso
David Frey

LAND studio

Greg Peckham
Joel Wimbiscus

Canalway Partners

Mera Cardenas

Flats Forward

Jim Haviland

Ohio City Inc.

Tom McNair
Ashley Shaw

Historic Warehouse District

Tom Yablonsky
Thomas Starinsky

CONSULTANT TEAM

OHM Advisors

Matt Hils, Principal
Arthur Schmidt, Project Manager

Merritt Chase

Nina Chase, Principal
Alex Kelley, Associate

TABLE OF CONTENTS

01.

INTRODUCTION + CONTEXT

02.

EXISTING CONDITIONS +
FUTURE CHARACTER

03.

DESIGN GUIDELINES

04.

APPENDIX

Adopted by Cleveland City Planning
Commission on March 18, 2022



01

INTRODUCTION + CONTEXT

INTRODUCTION

The Cleveland Flats Design Guidelines provide recommendations for riverfront properties along the Cuyahoga River in the Flats neighborhood of Cleveland, Ohio. The guidelines are a tool to enable the Flats to remain a distinctive neighborhood and a dynamic, yet cohesive, destination for people to experience.

The guidelines address three zones closest to the river, and cover typical site elements including site furnishings, lighting, paving, water access, railings, vegetation, signage, and public art. The guidelines are for a public audience, with specific recommendations for property owners, developers, designers, and facilities managers as they design, construct, and maintain riverfront spaces in the Flats.

The Design Guidelines for the Cleveland Flats are a recommendation that emerged from the 2021 Vision for the Valley planning effort. The plan imagined a future for the Cuyahoga River Valley, with dynamic urban landscapes that support both industry and multi-use development, all organized around publicly-accessible riverfront spaces and trails. The guidelines integrate the Cuyahoga River Valley's history and unique character, to create physical and visual

continuity, while allowing individual spaces to express their unique qualities.

CONTEXT MAP

The Cuyahoga River is one of the region's primary natural and economic resources. The River Valley has had many chapters. It's history begins with the industrial revolution in Cleveland, to the rampant pollution leading to numerous river fires in the 1960's, and today a remarkable renaissance spanning industry, redevelopment, environment, and public spaces. Over the past decade, the mix of trails, parks, water recreation, and adjacent development has increased with a flurry of studies and development in the works.



Vision for the Valley - Flats (2021)



Irish Town Bend Vision Plan (2021)



Canal Basin Park (2019)

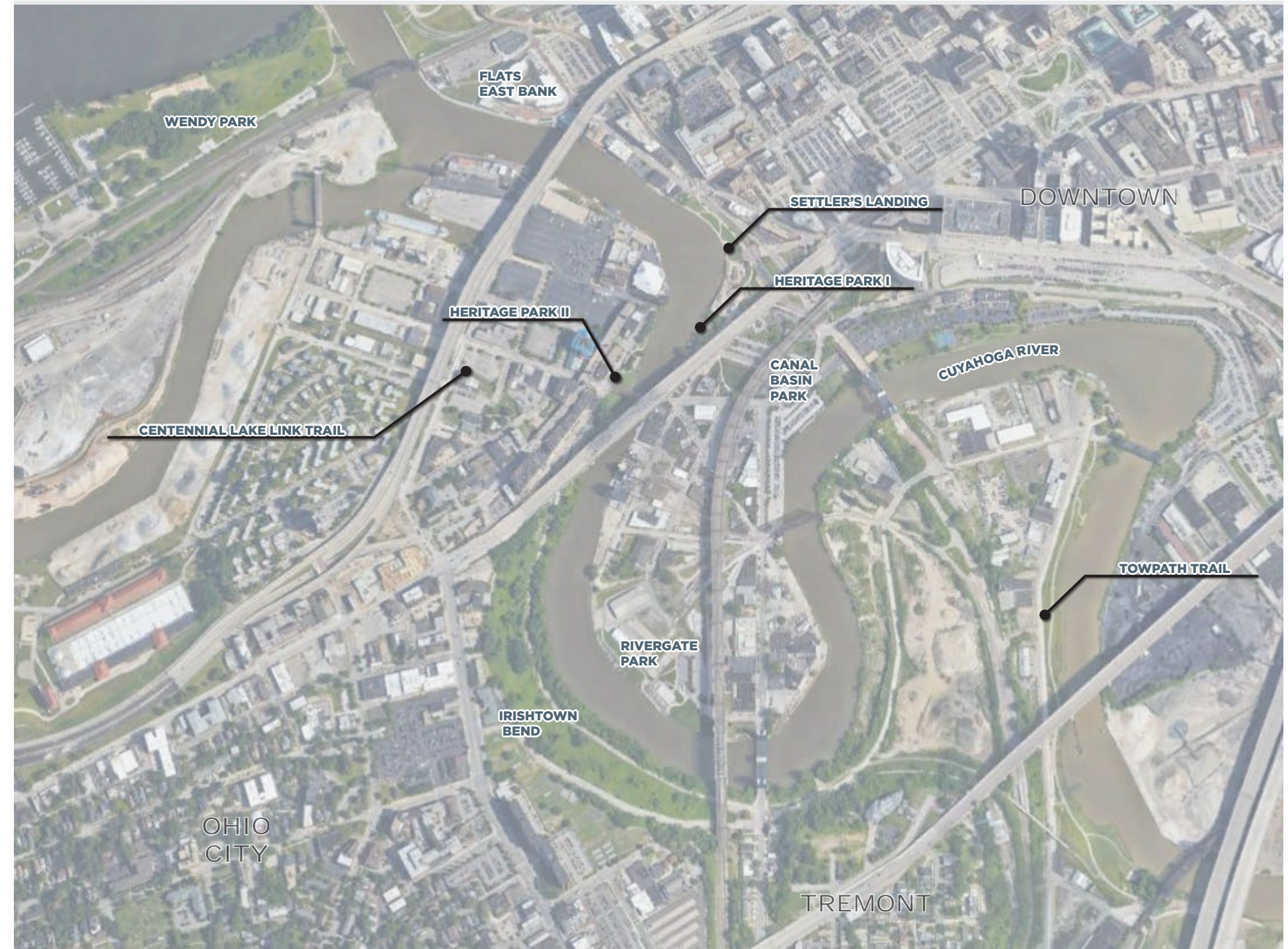

PROJECT STUDY AREA

The Cleveland Flats include a variety of riverfront spaces that are in various stages of development, and provide the community with critical greenspace and links to the riverfront. Significant parks at Irishtown Bend, the Towpath, and Canal Basin are scheduled in the coming years, with additional improvements planned for Heritage Park I and Heritage Park II. Recently implemented and future trails connect to these spaces and adjoining development to provide continuous access. These near-term projects, outlined to the right established the primary focus of the design guidelines.





02

EXISTING
CONDITIONS +
FUTURE
CHARACTER

**EXISTING CONDITIONS:
AN ECLECTIC MIX**

A wide variety of commercial uses, post-industrial properties, recreational access points, and entertainment districts line the Cuyahoga River. Each property's individual palette of materials, furniture types, lighting styles, paving, and vegetation creates the Flats' eclectic flavor. However, elements are not coordinated between the spaces to create a unifying identity. Pedestrian access to the water's edge in public spaces is also inconsistent and limited. Steel bulkheads along the navigable water channel facilitate the working waterfront, but create a barrier for recreational interests at most public riverfront spaces. At some locations, there is no shoreline protection, leading to shoreline instability.

Images on the following page document the existing conditions along the Cuyahoga River in the Flats.

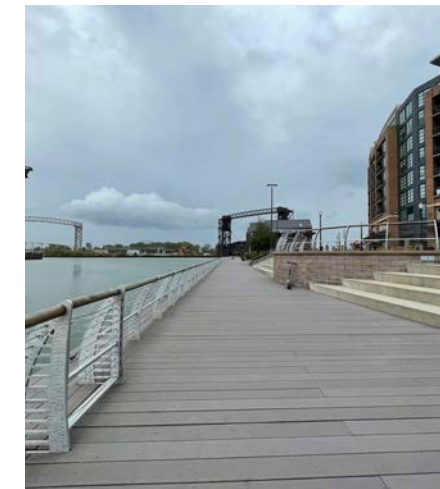

**FUTURE CHARACTER:
THEMES EXPLORED**

The Design Guidelines process started with an understanding of existing conditions and progressed into an exploration of the future character of the Flats. Three character themes (riverine, industrial, and civic) were introduced and pros and cons were discussed. The themes included ideas for future material palettes, riverfront aesthetics, sustainability, and longevity. Industrial and civic themes emerged as the preferred themes.

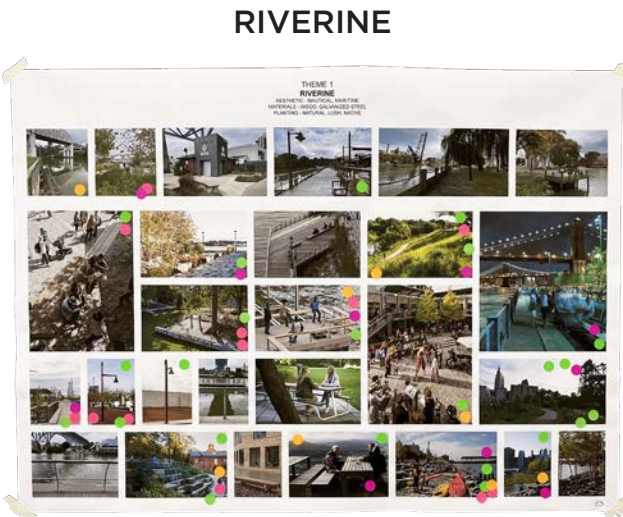

Aesthetic - Nautical, maritime
Materials - Wood, galvanized steel
Planting - Natural, lush native

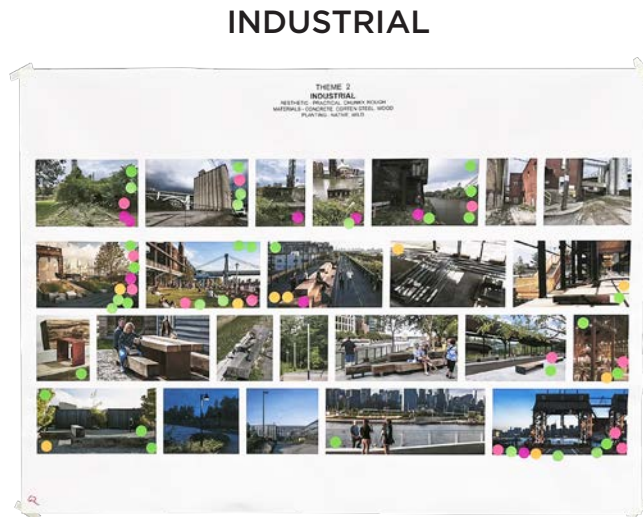

Aesthetic - Practical, chunky, rough
Materials - Concrete, cor-ten steel, wood
Planting - Native, wild



Aesthetic - Refined, sleek, geometric patterns
Materials - Wood, pavers, smooth stone, stainless steel
Planting - Manicured

“**Balance** is important so it doesn’t feel sterile”

“Keep the **industrial** character **authentic.**”

“Use **wood** to bridge between civic spaces and industrial spaces”

“You don’t need to add chunky industrial furniture. It may feel too forced.”

“Where can you touch the **water?**”



**RECOMMENDED
FUTURE CHARACTER:
“CIVIC INDUSTRIAL”**

The Design Guidelines provide recommendations for riverfront zones and elements that fit a composite “civic industrial” character. The combination of the civic and industrial character themes builds from the industrial legacy of the Flats while introducing a consistent civic scale and detail refinement to the riverfront. Without becoming too gritty, too bulky, or too sterile, the “civic industrial” theme emphasizes the working riverfront heritage with steel, wood, and stone materials in a refined selection of benches, lighting, railings, and paving. Any elements that are not recommended in these guidelines should meet the “civic industrial” character.

Precedent images on the following pages illustrate examples of the “civic industrial” aesthetic along riverfronts in other major American cities.

**RECOMMENDED FUTURE CHARACTER:
CIVIC INDUSTRIAL PRECEDENTS**

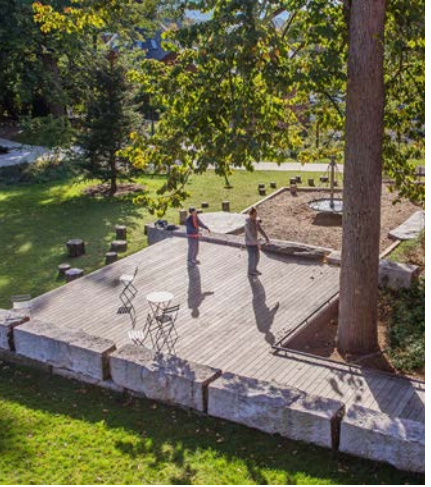
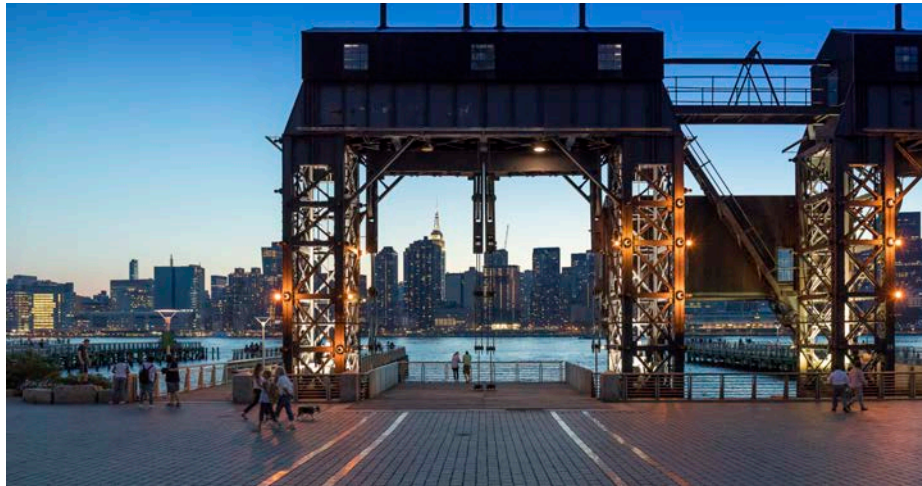



DESIGN GUIDELINES

03

HOW TO USE THE DESIGN GUIDELINES

The Design Guidelines are for a public audience, with specific recommendations appropriate for property owners, developers, designers, and facilities managers as they design, construct, and maintain riverfront spaces along the Cuyahoga River in the Flats. As the Flats develop over time, there is a need for a balanced approach to applying design guidelines. The following questions help to define which design guidelines should be followed. A design guidelines checklist is also provided at the end of this document for reference. The guidelines provide a vision for a high-quality, cohesive, and pedestrian-friendly public riverfront, while allowing flexibility for individual projects.

HOW RIGID ARE THE GUIDELINES? WHAT IS **FIXED**? WHAT IS **FLEXIBLE**?

The Design Guidelines provide a range of recommendations, depending on a project's location. While some guidelines are less strict, with fewer specific recommendations, other guidelines are rigid, with clearly defined recommendations. A range of fixed and flexible recommendations creates district-wide consistency for site furniture, tree and lighting spacing, trail conditions, railings, boardwalks, and

paving, while allowing for site-specific variety and individuality in larger, more unique parks.

WHERE IS A PROJECT LOCATED? IN WHAT **ZONE**?

A successful riverfront is made up of three zones: 1) a water zone that includes the river's edge, bulkhead, and riverine habitat; 2) an access zone that includes parallel and perpendicular connections along and to the river; and 3) a gathering zone where individual parks about the river and trail and provide larger gathering and programmable spaces.

The strictness of the Design Guidelines depends on a project's zone. The guidelines recommend that elements in the water zone and access zone are more strictly fixed in their selection, while elements in the gathering zone are more flexible. For more information, see descriptions of individual zones starting on page 24.

WHAT **ELEMENTS** ARE SELECTED?

Once a project's zone is determined, individual elements can be selected. Elements, such as benches, lighting, bike racks, trash receptacles, paving, railings, and vegetation establish the character and the pedestrian experience of the Flats. For more information, see descriptions of individual elements starting on page 32.

The recommended elements are selected to meet the "civic industrial" character of the Flats, as described on pages 15-17. The recommendations emphasize steel, wood, and stone materials. Any elements that are not recommended in these guidelines should meet the "civic industrial" character.

Elements are also recommended to meet the City of Cleveland sustainability goals. Native and non-invasive plant palettes increase habitat restoration and manage stormwater runoff. Permeable pavement and green infrastructure reduce stormwater runoff and urban heat island effects. Sourcing of sustainable wood products (ie: wood with Forest Stewardship Council Certification) reduces material life cycle implications.

Alternative selections for elements are included on the following pages for non-proprietary project bidding requirements. The guidelines additionally encourage elements that are manufactured in the United States.

Elements were selected to withstand the daily pressures of outdoor public spaces. Maintenance, material replacement, weathering, accessibility, and human comfort were considered. Proper detailing, construction management, and maintenance will maximize longevity of all elements.

ELEMENTS

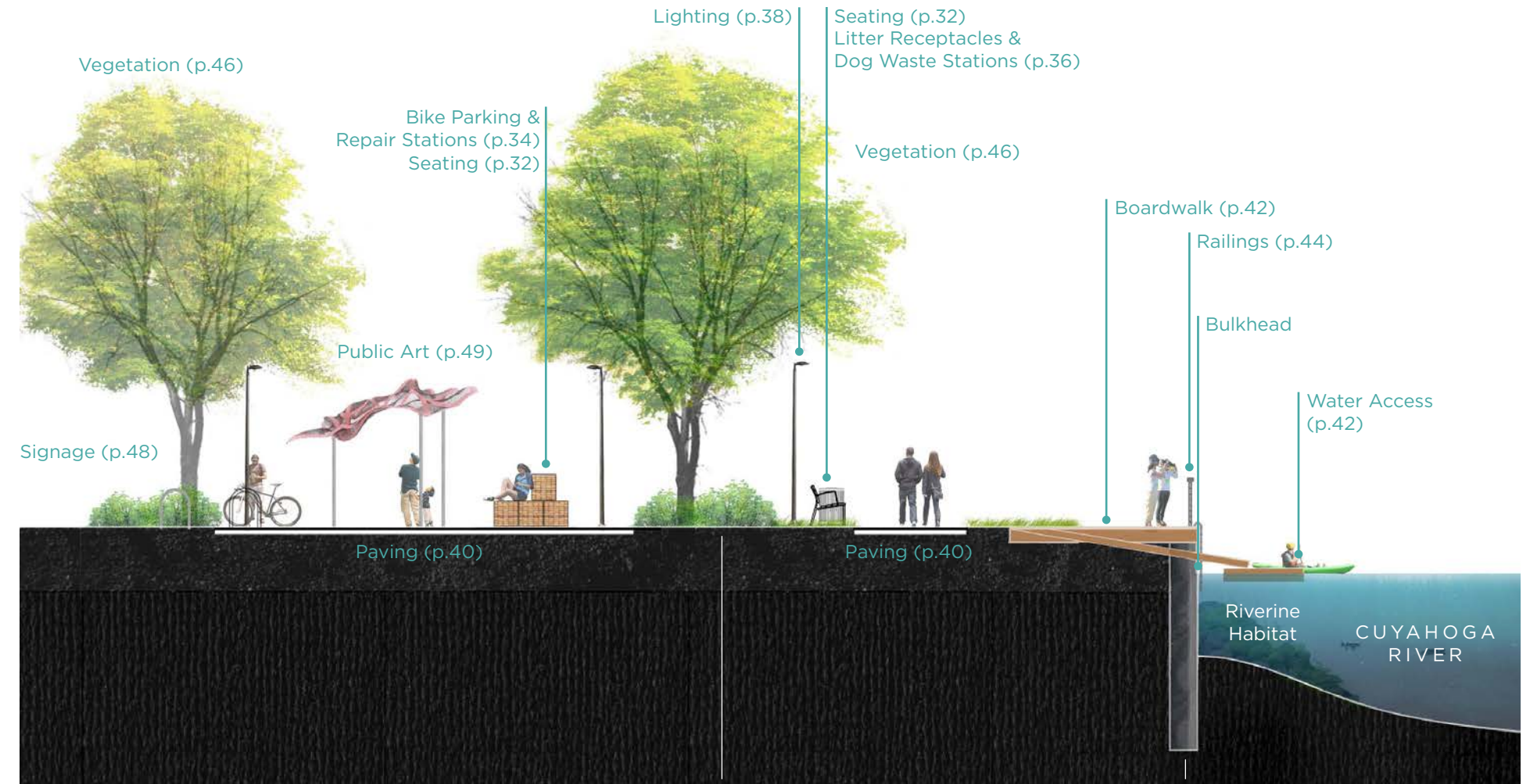

GATHERING ZONE (P.24) **ACCESS ZONE (P.26)** **WATER ZONE (P.28)**

FLEXIBLE ← → **FIXED**

Recommendations for elements in this zone are more flexible, allowing for more site-specific variety and individuality.

ZONES

Recommendations for elements in this zone are more fixed, creating more district-wide consistency.



ZONES

GATHERING ZONE
ACCESS ZONE
WATER ZONE

GATHERING ZONE

Gathering zones are larger, park-like spaces along the Cuyahoga River. These spaces provide areas to gather and should include space for a variety of activities. Gathering zones are typically set back from the river's edge (the access zone and the water zone). Examples of existing gathering zones in the Flats are Settler's Landing, Canal Basin Park, and Merwin's Wharf. Images of these spaces are provided on the following page for reference.

Elements that should be considered in gathering zones include individual seating, group seating, bike racks, trash receptacles, lighting, paving, public art, signage, and vegetation typical of a Midwestern upland riverfront. The Design Guidelines recommend that elements in the gathering zone are more flexible, allowing for more site-specific variety and individuality.

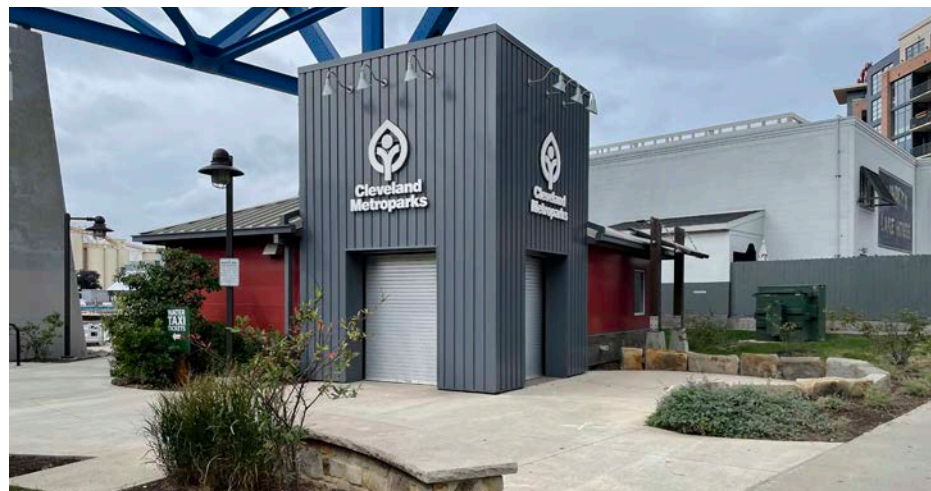
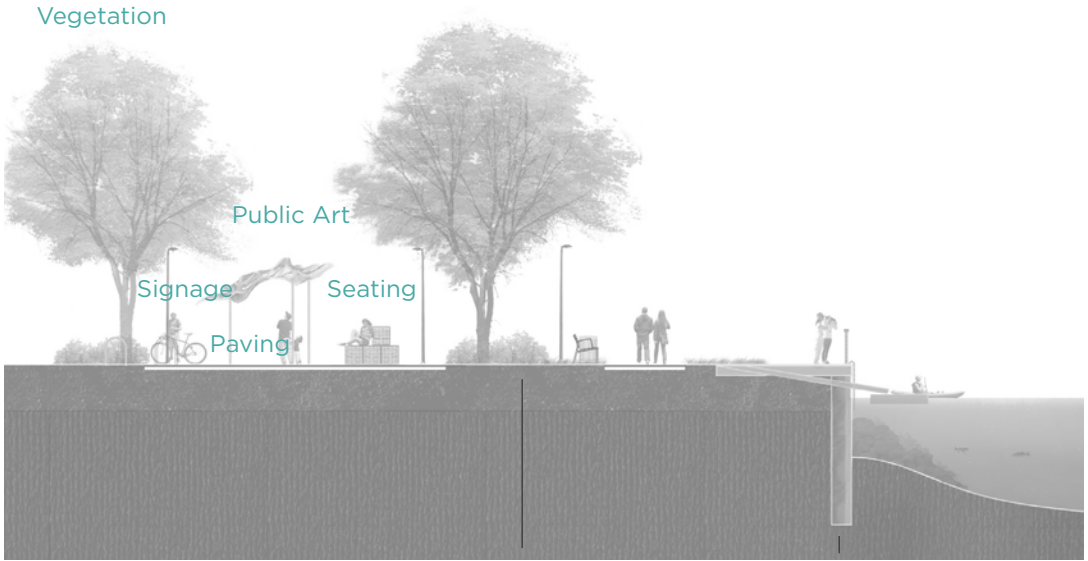

ACCESS ZONE

Access zones include both parallel riverfront trails and perpendicular streets that provide access to the riverfront.

Parallel to the river, the access zones are a continuous circulation route that provides easy pedestrian and cyclist access. Examples of existing parallel access zones include the concrete trail in between the river and Merwin's Wharf, and the concrete path along Settler's Landing. Images of these spaces are provided on the following page for reference.

Perpendicular to the river, the access zones are major streets that connect the riverfront open spaces into the adjacent neighborhoods. Examples of existing perpendicular access zones include Columbus Road, British Street, and Center Street.

Elements that should be considered in the access zones include individual seating, bike racks, trash receptacles, lighting, signage, paving, boardwalks, railings, and vegetation typical of an Ohio upland riverfront. The Design Guidelines recommend that elements in the access zone are more fixed, creating district-wide consistency.

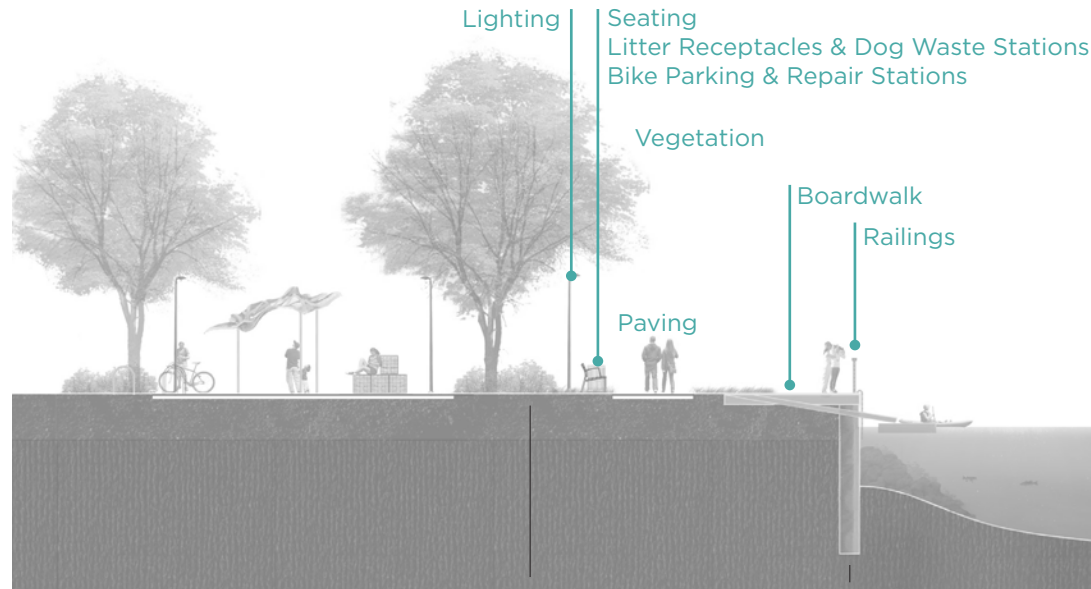

Elements should follow consistent spacing recommendations. While the width of the access zone can vary, it should be a minimum of 20 feet wide to provide safe access for circulation, seating, information kiosks, and mobility hubs. A 10-12 foot wide accessible path/trail for circulation is recommended.

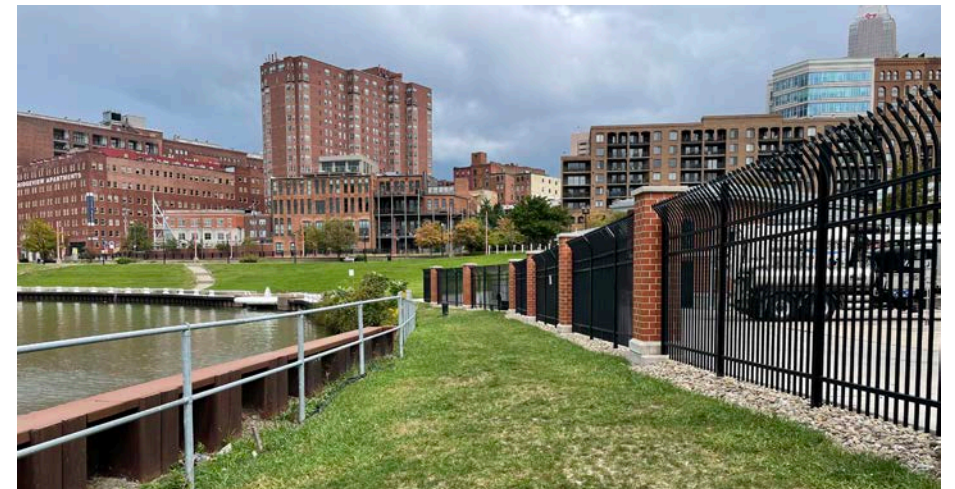

WATER ZONE

Water zones are the zones where the riverfront meets the river's edge. Parallel to the river, the water zone can provide protection from or access to the water. Examples of existing water zones include the docks at Merwin's Wharf and the boardwalk along Canal Basin Park. Images of these spaces are provided on the following page for reference.

The Design Guidelines recommend that elements in the water zone are more fixed, creating district-wide consistency. Elements that should be considered in the water zone include water access, riverine habitat, and bulkheads. Work related to the bulkhead and the water zone should adhere to the requirements of Ord. No. 573-10.

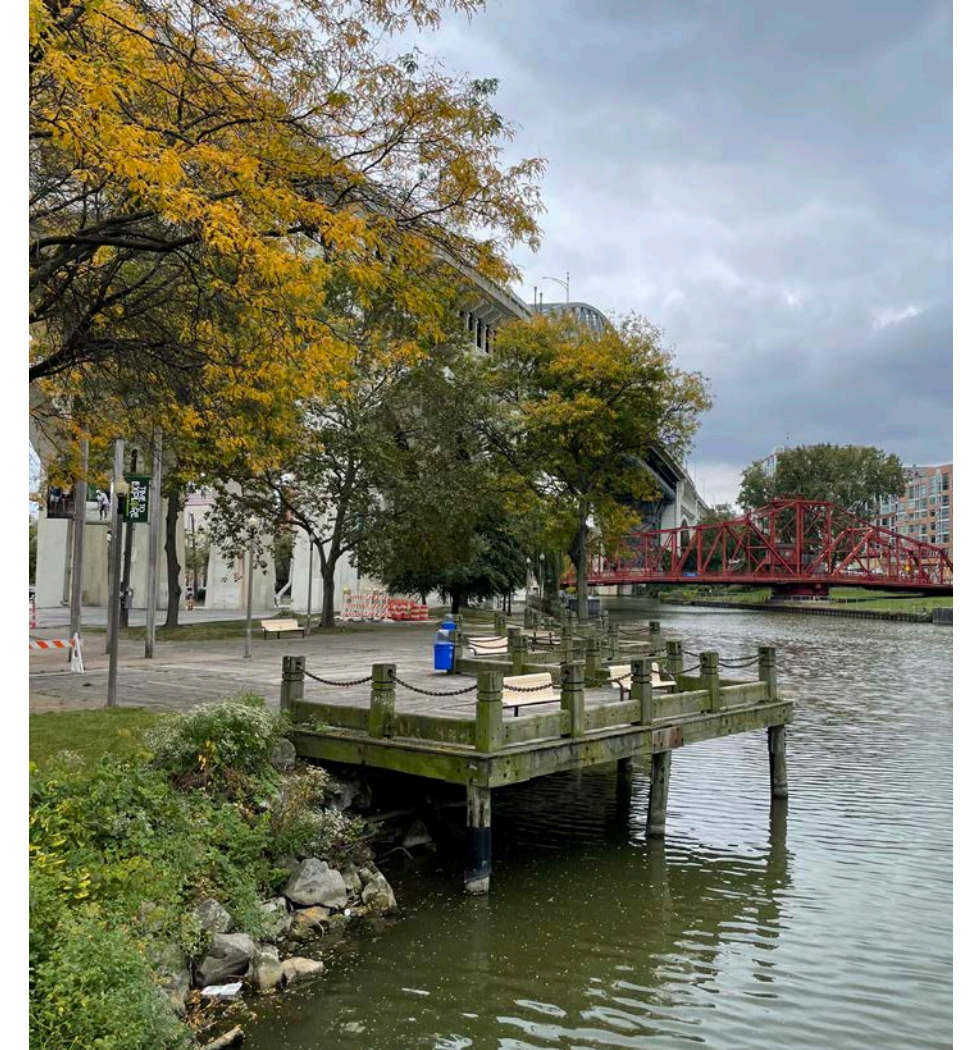



ELEMENTS

- SEATING
- BIKE PARKING & REPAIR STATIONS
- LITTER RECEPTACLES & DOG WASTE STATIONS
- LIGHTING
- PAVING
- RAILINGS
- BOARDWALK & WATER ACCESS
- VEGETATION
- SIGNAGE
- PUBLIC ART

SEATING

OVERVIEW

Seating should be consistent throughout the Flats to achieve a cohesive, distinct experience. Benches and picnic tables have been selected to meet the “civic industrial” aesthetic with wood and powder coated metal details. To make the landscape inviting and accessible, generous seating should be provided at regular intervals. Seating can consist of individual benches or groups of benches. Picnic tables can be provided for group seating.

APPLICATION

Seating Options 1 and 2 are recommended for individual seating. Individual benches should be utilized along the access zone. Backs are recommended to meet accessibility requirements. Arms, additional configurations, and lengths are available and can be used for site-specific seating solutions. Black powder coated steel is recommended.

Seating Options 3 and 4 are recommended for group seating.

FIXED VS. FLEXIBLE (see pg. 20)

Seating style, as opposed to whether it is mounted to the ground or movable, should be fixed in the water zone and access zone and flexible in the gathering zone. If consistent spacing is possible in the water zone and access zone, benches should be located 40 feet on center at a minimum. If alternative benches are selected in the gathering zones, wood and powder coated metal should be utilized.



RECOMMENDED BENCH:
S1. Seating Option 1



RECOMMENDED BENCH:
S2. Seating Option 2



RECOMMENDED SEATING ON
WALLS: Seatwalls with integrated
wood benches



RECOMMENDED SEATING ON
WALLS: Planters with integrated
wood benches



RECOMMENDED TABLE
SEATING: S3. Seating Option 3

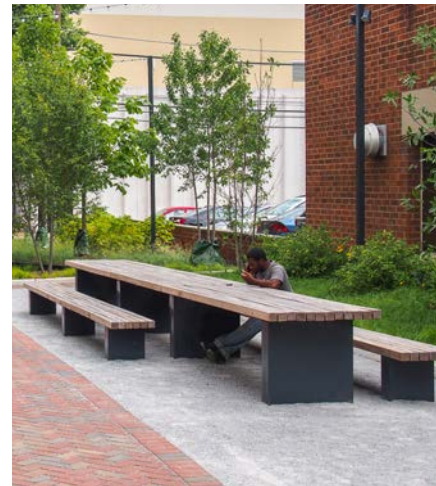

RECOMMENDED TABLE
SEATING: S4. Seating Option 4



AVOID: Residential wood



AVOID: Chunky wood



AVOID: Metal seats



AVOID: Individual fixed seats

BIKE PARKING & REPAIR STATIONS

OVERVIEW

A simple hoop rack embedded into the concrete is the most secure and cost-effective solution. Bike racks should be placed close to entrances and destinations with care taken so that they do not become obstacles obscuring important views or pedestrian routes in gathering zones or access zones. If space allows, covered bike storage is recommended in areas with high bike traffic.

Sparing use of bike repair stations will provide the public with a useful amenity, without becoming a visual nuisance.

APPLICATION

Bike racks should be similar to Bike Rack Options 1 and 2. The rack should be stainless steel, u shaped, and embedded into concrete, not attached to the concrete by fasteners. A customized interior bar may be applied for branding purposes if desired.

Bike shelters should be treated as an architectural feature, and designed or specified on a site-by-site basis, within the site's context.

Repair stations' finish and color should match the finish and color of adjacent bike racks. Include tamper proof tools, bike hanger arms, and tire pump.

FIXED VS. FLEXIBLE

A bike rack is considered a fixed element and should be consistent in all zones.

Covered bike storage is considered a flexible element. Locate this element only on the edge of access zones and in gathering zones.

A bike repair station is considered a fixed element, should be consistent, and located only in access and gathering zones.



RECOMMENDED:
B1. Bike Rack Option 1



RECOMMENDED:
B2. Bike Rack Option 2



RECOMMENDED:
B3. Bike Rack Option 3



RECOMMENDED:
RS1. Bike Repair Station Option 1



RECOMMENDED:
RS2. Bike Repair Station Option 2

LITTER RECEPTACLES & DOG WASTE STATIONS

OVERVIEW

The consistent but sparing use of litter receptacles and dog waste stations will enable users to keep the Flats tidy without overburdening maintenance crews. Too many litter receptacles and dog waste stations can become a visual nuisance and become difficult to maintain.

APPLICATION

Litter receptacles and dog waste stations should be black powder coated similar to Litter Receptacle Options 1, 2, and 3.

FIXED VS. FLEXIBLE

Litter receptacles are fixed elements in the water zone and access zone. While they are flexible in the gathering zone, they should not be relied upon to provide interest.

Dog waste stations are considered fixed elements and should be consistent in all zones.



RECOMMENDED:
LR1. Litter Receptacle Option 1



RECOMMENDED:
LR2. Litter Receptacle Option 2



RECOMMENDED:
LR3. Litter Receptacle Option 3

LIGHTING

OVERVIEW

Lighting can consist of pole lights, bollards, catenary lights, and other decorative lights. Pole lights provide consistent light levels without interrupting viewsheds or cluttering spaces. Alternative lighting solutions are best used sparingly when the lighting design is closely related to the associated program. LED luminaires are recommended and warmer white color temperatures (2,700-3,500 K) are recommended. To maintain consistent color temperature and light intensity, the same color temperature should be used for an entire project area and should be closely coordinated with adjacent property lighting temperatures. Integrated charging ports, power outlets, signage brackets are recommended. Dark Sky compliant light fixtures are recommended.

APPLICATION

Lighting similar to Lighting Options 1 and 2 is recommended for pole lights. Pedestrian scale round light poles with a maximum height of 15' are recommended. Pole light spacing of 80-100' is recommended. Black powder coated color is recommended for luminaires and pole.

Lighting similar to Lighting Options 3 and 4 is recommended for bollard lights. Black powder coated metal is recommended.

FIXED VS. FLEXIBLE

Lighting in the water zone and access zone is fixed. Lighting is flexible in the gathering zone.



RECOMMENDED:
L1. Lighting Option 1



RECOMMENDED:
L2. Lighting Option 2

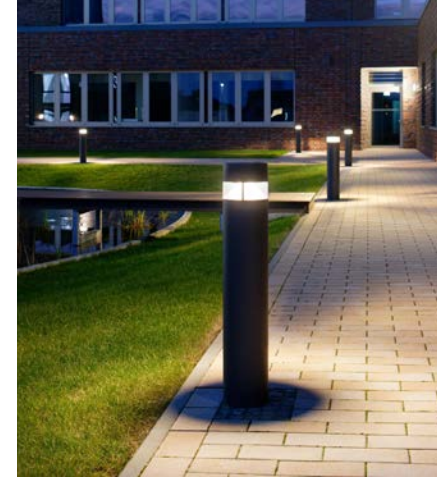

RECOMMENDED:
L3. Lighting Option 3



RECOMMENDED:
L4. Lighting Option 4

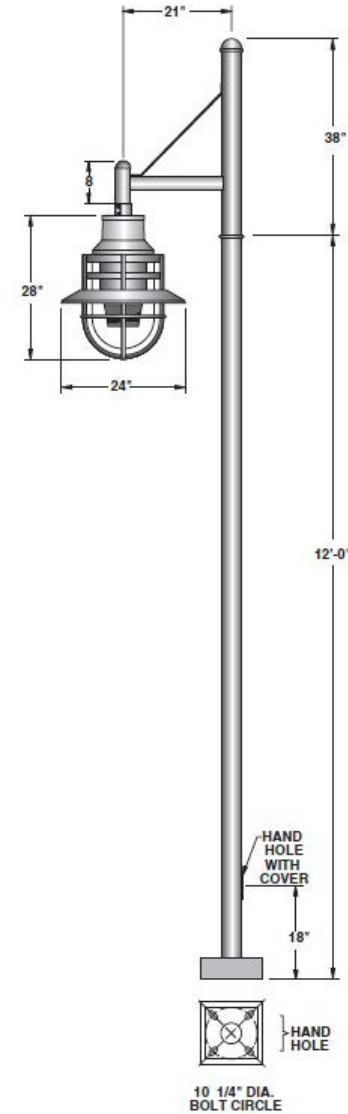

RECOMMENDED:
L5. Lighting Option 5



AVOID: Vehicular scaled poles



AVOID: Non-shielded, Dark Sky non-compliant fixtures

PAVING

OVERVIEW

Paving creates the hardscaped ground plane of the riverfront. Paving can include concrete, asphalt, or pavers such as concrete unit pavers or brick/clay pavers. Consistent paving materials in the access zone will provide a easily recognizable riverfront experience. Different paving materials in the gathering zone will allow for site specific variety.

APPLICATION

Paving in the water zone and access zone should be concrete with few exceptions. The typical finish should be a broomed finish with saw-cut joints and no tooling of joints or edges; surface applied color additives and stamped concrete should not be used. In areas where higher investment is desired, the finish may be an exposed aggregate or a natural stone. If the access zone includes a multi-purpose recreational trail, asphalt is recommended for the trail. In the gathering zone, paving can be more flexible. Unit pavers, crushed stone, and stone fines with a wider range of colors and finishes can be used to create a distinct identity. Permeable concrete unit pavers with hidden interlocking grooves are recommended where appropriate. Open grass “grass-crete” permeable pavers should be avoided.

FIXED VS. FLEXIBLE

In the access zone, paving is fixed with a limited material palette of concrete and asphalt. In the gathering zone, paving is flexible and can include concrete unit pavers and brick/clay pavers.



RECOMMENDED: Asphalt (for trails only)



RECOMMENDED: Broom finish concrete

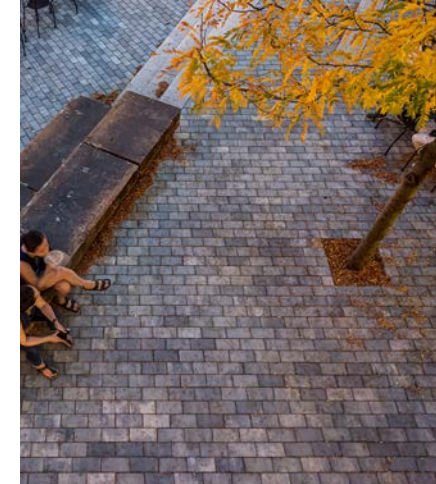

RECOMMENDED: Permeable concrete unit pavers with square edges, hidden permeable joints, and minimal patterns



RECOMMENDED: Concrete unit pavers with square edges and minimal patterns

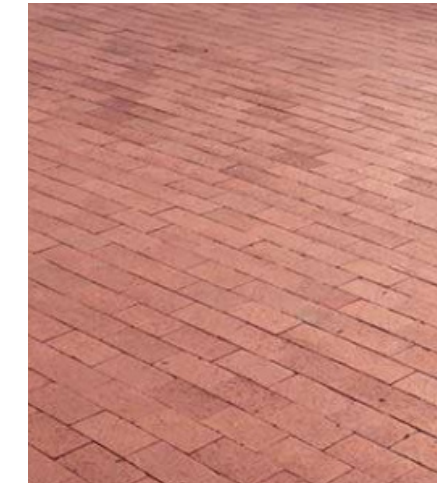

RECOMMENDED: Clay brick pavers with square edges



RECOMMENDED: Integral colored concrete



AVOID: Surface applied colored concrete



AVOID: Mixed materials



AVOID: Stamped concrete or asphalt



AVOID: Rustic or beveled edges



AVOID: Open permeable pavers or grass-crete products

BOARDWALK & WATER ACCESS

OVERVIEW

Access to the water is an important consideration along the Cuyahoga River and should be detailed carefully to create continuity along the edge. Often a boardwalk will project above the water relying on a railing to define its edge. However, there are moments when the access zone brings users to the water level.

APPLICATION

Boardwalks, docks, and other water access elements built above water, should correspond with the railing element. Surface material should be Forest Stewardship Council (FSC) certified wood with stainless steel fasteners, and accessories should be stainless steel or galvanized steel. When access is provided by removing the bulkhead and bringing users to the water level, concrete and stone may be used.

FIXED VS. FLEXIBLE

Boardwalks, docks, and other water access elements are considered fixed elements. Therefore, there should be little variation in the materials used. Though, scale and programming requirements will affect the overall layout and design of boardwalks and docks.

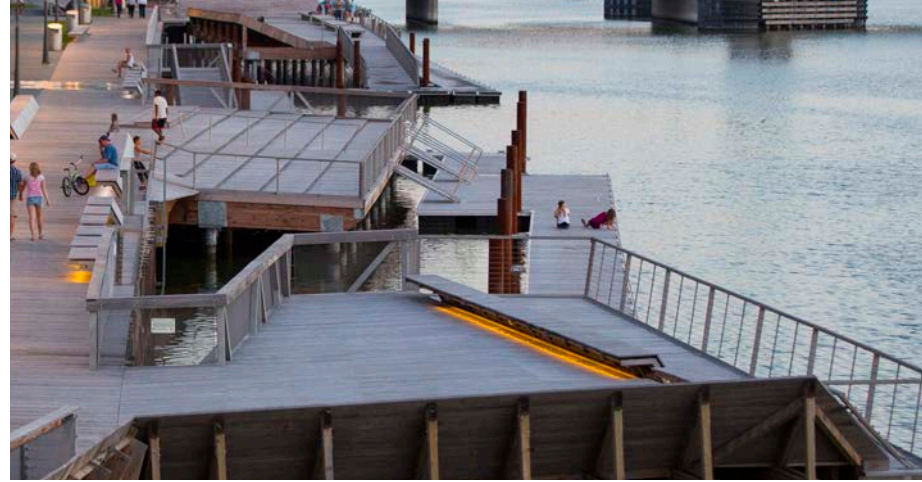

RECOMMENDED: Wood decking and stainless steel/wood railing



ALTERNATIVE: Custom - Naturalized sloped ramp access



ALTERNATIVE: Custom - Stepped access



RECOMMENDED: FSC certified hardwood



AVOID: Engineered products

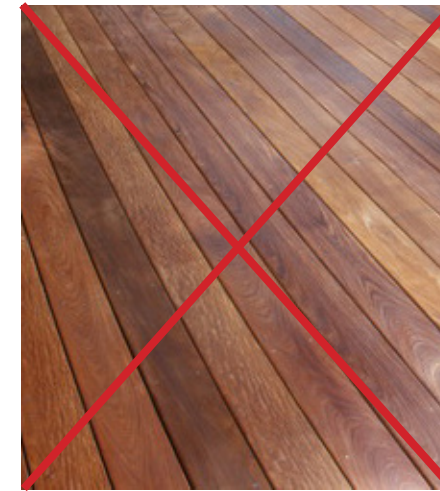

AVOID: Exotic hardwoods

RAILINGS

OVERVIEW

Much of the river’s edge is a protective bulkhead intended to accommodate shipping. The bulkhead typically raises the grade high enough above the water level to require a railing to protect pedestrians from falling into the river. The railing has a significant impact on landscape identity because of its location and the prevalence of its use.

APPLICATION

Railings should be stainless steel, galvanized, or sealed cor-ten steel frame with a wood handrail on top. Painted, powder-coated, or other finishes should be avoided due to maintenance concerns.

The Cleveland Metroparks railing shown to the right is the baseline recommendation. The other three recommended custom railings shown to the right are higher cost than the baseline.

For transitions between low- and high-cost railings, project landscape architect should address with the appropriate detail.

FIXED VS. FLEXIBLE

Railings are considered a fixed element, and there should be little variation in the materials used. However, the complexity and refinement of the materials may vary according to project budget and visibility.



RECOMMENDED: Cleveland Metroparks railing - stainless steel and wood



RECOMMENDED: Custom - Stainless steel



RECOMMENDED: Custom - Stainless steel

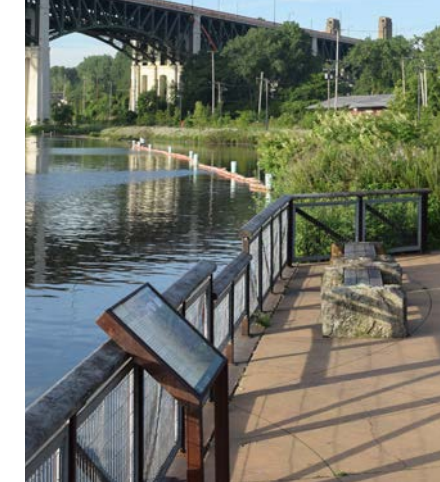

RECOMMENDED: Custom - Galvanized steel or cor-ten steel

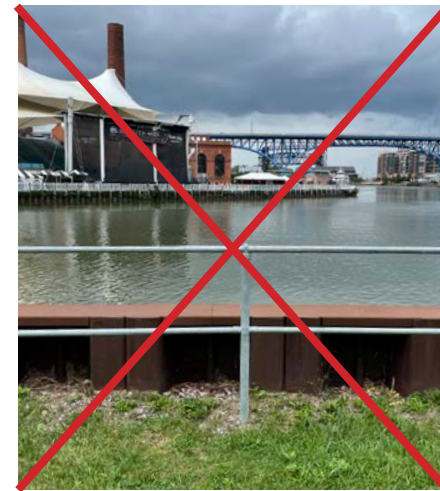

AVOID: Pipe railings



AVOID: Residential fencing

VEGETATION

OVERVIEW

In all conditions, vegetation is an effective way to create identity. However, given the broad range of environmental conditions along the Cuyahoga River in the Flats, planting recommendations are widely variable. Using native and non-invasive species to give the Cleveland Flats a clear identity suited to the Cuyahoga River is recommended. Trees should be selected with open canopies and limbed up to maintain views of the river and visually attractive elements (ie: key buildings, bridges, industrial relics). Vegetation should be arranged to screen less visually attractive elements (ie: loading and service bays, storage areas, trash enclosures, and mechanical equipment).

APPLICATION

In densely populated or industrial areas, plant palettes should be simple and consist of low-maintenance planting, including woody shrubs and trees with the ability to tolerate urban conditions and post-industrial soils. Hardy, drought tolerant vegetation that supports wildlife and limits nuisance animals is recommended. In less dense areas, vegetation should create ecologies, such as meadows, and riparian forests. In all passive use zones, lawn should be used sparingly. Native and non-invasive plantings should be integrated into green infrastructure facilities (ie: rain gardens and bioswales) where appropriate.

FIXED VS. FLEXIBLE

Vegetation is a flexible element. Though, it should relate to the adjacent conditions and create continuity in the access zone.



RECOMMENDED: Native, non-invasive perennial riverine vegetation



AVOID: Water intensive annuals



RECOMMENDED: Native, non-invasive, perennial riverine vegetation



RECOMMENDED: Native, non-invasive, perennial riverine vegetation with seasonal interest



AVOID: Water intensive annuals and maintenance intensive borders



AVOID: "Plants on parade"

SIGNAGE

OVERVIEW

Multiple signage and wayfinding planning efforts have been completed in recent years and are available to provide guidance for areas within the Flats. Depending on a project’s location, the following signage and wayfinding plans should be referenced:

- Cleveland Metroparks Signage & Wayfinding Standards
- Flats Forward Wayfinding Program
- Destination Cleveland Visitors Signage & Wayfinding
- Off Road Trails & Bikeways Wayfinding Sign System Standards Manual for Greater Cleveland/Cuyahoga County

The “Off Road Trails & Bikeways Wayfinding Sign System Standards Manual for Greater Cleveland/Cuyahoga County” (The Manual) provides instructions for signs for trail and bikeway networks throughout Cleveland and Cuyahoga County. The intent is to create a standard wayfinding sign program for trails and bikeways that connects the Greater Cleveland area. The standards include the look and feel of the system of signs, guidelines for content, criteria for naming/nomenclature, and information hierarchy. In instances where a nonstandard sign is necessary, the manual provides a standard for design intent with custom signs or deviations from the sign family requiring approval by the Off Road Trails Wayfinding Taskforce.



Off Road Trails & Bikeways Wayfinding Sign System Standards Manual for Greater Cleveland/Cuyahoga County

APPLICATION

Signage should be provided at key points in the access zone and gathering zone. Access zone signage should indicate major circulation routes parallel and perpendicular to the river. Within the gathering zone, signage should communicate destination points and nearby sites of interest. Interpretive signage should highlight historic relics, past land use, and diverse cultural narratives.

FIXED VS. FLEXIBLE

Signage is considered a fixed element across all zones.

PUBLIC ART

OVERVIEW

Public art has the power to enliven a landscape and experience of a place. Public art should relate to the industrial context and utilize existing artifacts as borrowed elements in the Flats, where possible. Public art that encourages participation and the potential for programming is encouraged and highly recommended.

APPLICATION

Public art can be applied in any zone but should not disrupt the continuity of the access zone. Opportunities for public art include iconic gateways or smaller, more subtle artistic elements in the landscape. The artist and landscape architect should determine the placement of public art and the design of the supporting landscape.

FIXED VS. FLEXIBLE

Public art is considered a flexible element across all zones.

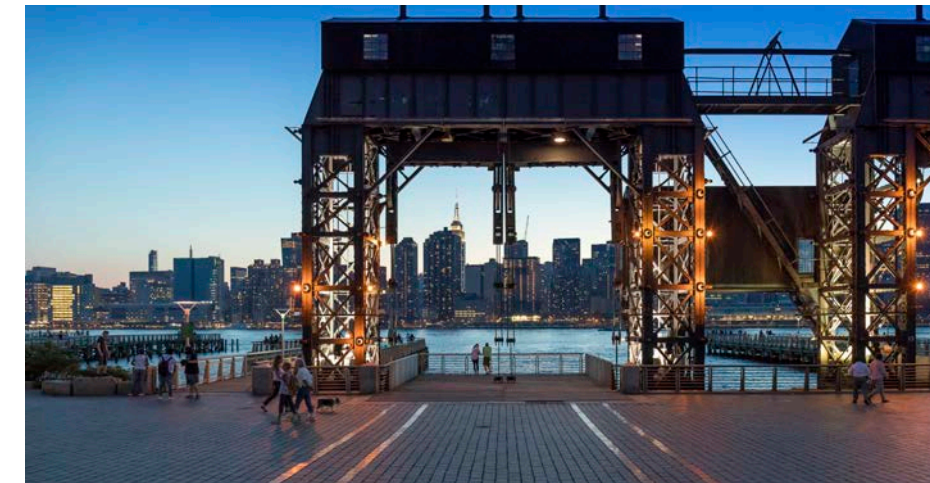

RECOMMENDED: Public art that celebrates and reinterprets industrial artifacts



RECOMMENDED: Public art that encourages participation



RECOMMENDED: Programming and events as public art experience



04

APPENDIX

RECOMMENDED ELEMENTS
DESIGN CHECKLIST

DESIGN GUIDELINES CHECKLIST

The following checklist corresponds to recommendations in the Cleveland Flats Design Guidelines. The Design Guidelines provide recommendations for riverfront properties along the Cuyahoga River in the Flats neighborhood of Cleveland, Ohio.

The guidelines address three riverfront zones and typical riverfront site elements. The recommended elements are organized according to three riverfront zones: the gathering zone, the access zone, and the water zone. The elements include site furnishings, lighting, paving, water access, railings, vegetation, signage, and public art. The guidelines are for a public audience, with specific recommendations for property owners, developers, designers, and facilities managers as they design, construct, and maintain riverfront spaces in the Flats.

For more detailed information regarding zones and elements, refer to the full Cleveland Flats Design Guidelines document.

GATHERING ZONE (P.24)

RECOMMENDED ELEMENTS

- Seating (p.32)
- Bike Parking & Repair Stations (p.34)
- Litter Receptacles & Dog Waste Stations (p.36)
- Lighting (p.38)
- Paving (p.40)
- Vegetation (p.46)
- Signage (p.48)
- Public Art (p.49)

ACCESS ZONE (P.26)

RECOMMENDED ELEMENTS

- Seating (p.32)
- Bike Parking & Repair Stations (p.34)
- Litter Receptacles & Dog Waste Stations (p.36)
- Lighting (p.38)
- Paving (p.40)
- Boardwalk (p.42)
- Railings (p.44)
- Vegetation (p.46)
- Signage (p.48)
- Public Art (p.49)

WATER ZONE (P.28)

RECOMMENDED ELEMENTS

- Water Access (p.42)
- Bulkhead
- Riverine Habitat

Cleveland Flats Design Guidelines
City of Cleveland
March 18, 2022